



DC FAN DELTA TYPE PFB 2048HT

- * Bearing Type
Ball Bearings
- * Material
Impeller : Plactic (UL 94V-0)
Frame:Die-Cast Aluminum
- * Lead Wires :
UL 1430 AWG #22 OR Equivalent
Red Wire Positive (+)
Black Wire Negative (-)
- * Weight : 1600g (56.50 oz)



PFB 200 x 200 x 70MM SERIES
INDOSAT SPECIFICATION



■ DIMENSIONS DRAWING

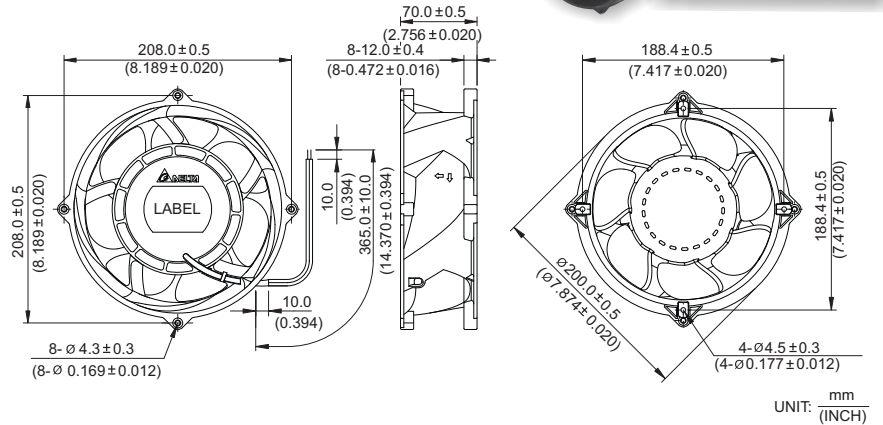

■ P & Q CURVE (AT RATED VOLTAGE)

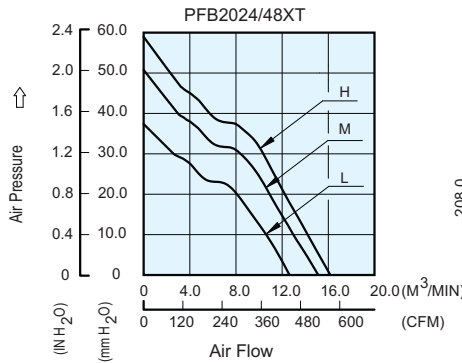

■ MOUNTING PANEL CUTOUT

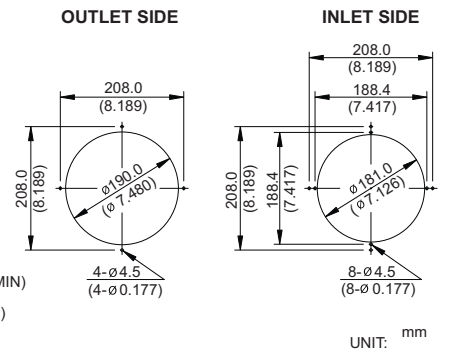

MODEL		Rated Voltage	Operating Voltage Range	Rated Current	Rated Input Power	Speed	Maximum Air Flow		Maximum Air Pressure		Noise
PART NO.	FUNCTION	VDC	VDC	Amp	Watt	R.P.M.	m ³ /min	CFM	mmH ₂ O	IN H ₂ O	dB-A
PFB2048HT	-R00 / -F00	48	28.0 - 60.0	2.38	113.28	4800	16.150	569.50	58.20	2.290	68.5

* Function type is optional.
 * The max. air flow and the speed are measured in free air ; max. air pressure is measured at zero air flow.
 * Noise is measured in anechoic chamber in free air, one meter from intake side.
 * All readings are typical values at rated voltage.
 * Specifications are subject to change without notice.

AUTHORIZED DISTRIBUTOR



PT BERATHI

Jl. Kresek Raya No. 21 K Duri Kosambi
 Cengkareng-Jakarta 11750
 Telp (62-21) 5437 2708, 7027 5036
 Fax (62-21) 5438 1361